

Symmetry Control of the Coloring Problem: The Electronic Structure of MB_2C_2 ($M = Ca, La, \dots$)

Jeremy K. Burdett,* Enric Canadell,[†] and Timothy Hughbanks

Contribution from the Department of Chemistry, The University of Chicago, Chicago, Illinois 60637. Received November 4, 1985

Abstract: The correlation of symmetry with electronic stability of the coloring of an extended network with symmetry equivalent positions is studied by using the 48^2 net found in MB_2C_2 ($M = Ca, La, \dots$) as an example. The results are readily extended to other systems, and the conclusions are compared with those derived from the moments method.

Given a molecular or extended network and two different types of atoms or chemical groups, what is the best way to distribute them in the network for a fixed stoichiometry? This question, which has been termed "the coloring problem",¹ is frequently faced by both molecular and solid-state chemists. 1-3 are some organic (substituted square singlet cyclobutadienes $C_4D_2A_2$), inorganic (S_4X_4 , $X = N$,^{6a} P ,^{3b} As ^{3c}), and solid-state (ScB_2C_2)^{4a} examples.^{4b} The simplest way to tackle this problem is by performing calcu-

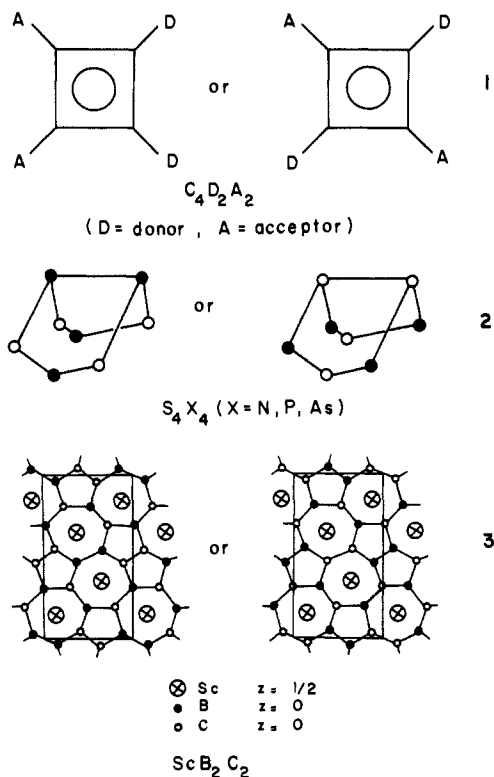

lations on an isoelectronic unsubstituted parent network. The more electronegative atoms or groups will prefer the positions with the higher electron density. These calculations are not only useful as a predictive tool but usually highlight the electronic factors which control the substitution pattern. This method has been called⁵ "topological charge stabilization". However, if some symmetry element exists which makes equivalent every position in the parent network, such a strategy will obviously be useless. Now the question will be the following: what is the best way to lower the symmetry of the network for a fixed coloring stoichiometry? In fact, symmetry does not complicate our understanding of these systems but often considerably simplifies it as shown by Hoffmann⁶ for 1.

In the present work we explore in some detail the relation between symmetry and stability of a coloring for an extended network with symmetry equivalent positions. To approach this problem we have chosen to look at the electronic structure of MB_2C_2 ($M = Ca, La, \dots$) systems.⁷⁻¹² This study will complement our earlier one¹ which used the method of moments to view the stability of colorings of different types.

Structure of MB_2C_2 Systems

Except for $M = Sc$, 3, all other MB_2C_2 phases known ($M = Ca, Y, La, Ce, Pr, Nd, Sm, \dots$) are isostructural. The structure can be derived from the well-known CaB_6 arrangement by removing the apical atoms of each boron octahedron. Substitution of half the boron atoms by carbon gives the MB_2C_2 structure, 4.

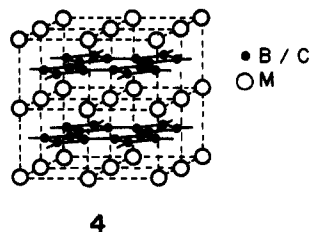

Consequently, the three-dimensional structure can be viewed as a series of layers alternately containing the M atoms and the 48^2 boron-carbon networks. Now the obvious question is the following: how are the boron and carbon atoms distributed in the 48^2 net? Bauer and Nowotny⁷ proposed for YB_2C_2 an arrangement with alternating boron and carbon atoms within the squares and with B-B and C-C contacts between the squares as shown in 5. The cell has to be doubled in the c direction and the second B/C net at $z = 1/2$ is rotated 90° with respect to that at $z = 0$. Bauer and co-workers proposed the same structure for LaB_2C_2 ⁸ and CaB_2C_2 .⁹ Although it could be argued that the lanthanide d orbitals could have some role in influencing the bonding with the planar net and hence in controlling the coloring, this is not the case for CaB_2C_2 .

- (1) Burdett, J. K.; Lee, S.; McLarnan, T. J. *J. Am. Chem. Soc.* **1985**, *107*, 3083.
- (2) Gompper, R.; Seybold, G. *Angew. Chem., Int. Ed., Engl.* **1968**, *80*, 824.
- (3) (a) Sharma, B. D.; Donohue, J. *Acta Crystallogr.* **1963**, *16*, 891. (b) Ito, T.; Morimoto, N.; Sadanaga, R. *Acta Crystallogr.* **1952**, *5*, 775. (c) Minshall, P. C.; Sheldrick, G. M. *Acta Crystallogr.* **1978**, *B34*, 1326.
- (4) (a) Smith, G. S.; Johnson, Q.; Nordine, P. C. *Acta Crystallogr.* **1965**, *19*, 668. (b) See ref 1 for a larger series of examples.
- (5) Gimarc, B. M. *J. Am. Chem. Soc.* **1983**, *105*, 1979.
- (6) Hoffmann, R. *Chem. Commun.* **1979**, 240.
- (7) Bauer, J.; Nowotny, H. *Monatsh. Chem.* **1971**, *102*, 1129.
- (8) Bauer, J.; Bars, O. *Acta Crystallogr.* **1980**, *B36*, 1540.
- (9) Breant, T.; Pensec, D.; Bauer, J.; Debuigne, J. C. *R. Acad. Sci., Ser. C* **1978**, *287*, 261.
- (10) Bauer, J.; Debuigne, J. C. *R. Acad. Sci., Ser. C* **1972**, *274*, 1271.
- (11) Fishel, N. A.; Eick, H. A. *J. Inorg. Nucl. Chem.* **1969**, *31*, 891.
- (12) (a) Smith, P. K.; Gilles, P. W. *J. Inorg. Nucl. Chem.* **1967**, *29*, 375. (b) Smith, P. K. Ph.D. Thesis, University of Kansas, Lawrence, Kansas, 1964.

[†] Present address: Laboratoire de Chimie Théorique, Université de Paris-Sud, 91405 Orsay, France.

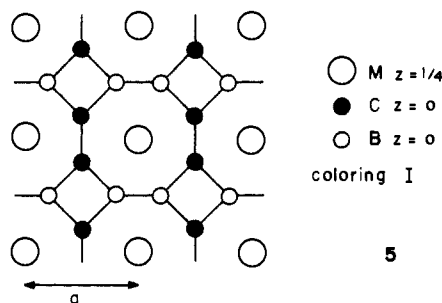

Here it is likely that the electropositive calcium atom is only acting as a two-electron donor with respect to the B_2C_2 net. This view is consistent with the known physical properties of the closely related CaB_6 . In consequence we believe the preference for a given coloring should be an intrinsic property of the $B_2C_2^{2-}$ 48^2 net.

In view of the presence of donor-donor and acceptor-acceptor contacts in the structure, the proposed coloring **5** is surprising. More specifically, this coloring seems to be in conflict with well-known ideas from organic chemistry concerning the stable patterns for donor-/acceptor-substituted cyclobutadiene and cyclooctatetraene systems. Hoffmann has shown⁶ that for a half-filled π system¹³ the all alternate structure **6**, where X and Y are



atoms of different electronegativity, is more stable than **7**, with X-X and Y-Y contacts. The same result applies to a hypothetical planar cyclooctatetraene system. The proposed coloring **5** fulfills this requirement as far as the squares are concerned (in fact they are distorted to rhombuses) but not with respect to the octagons also present in the net.

A different coloring which fulfills both requirements is **8**, where the unit cell doubling has occurred not along c but in a perpendicular direction. Only donor-acceptor contacts are present in

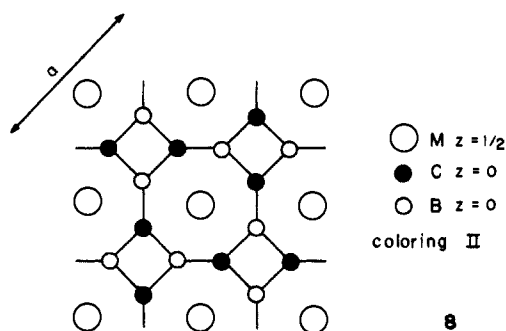

this structure. It has to be pointed out that although a complete X-ray study was not possible, **8** was the first structure proposed^{12b} for LnB_2C_2 systems ($Ln = \text{lanthanide}$).

Although structure **5** has been favored in the writings by Bauer, Nowotny, and co-workers,⁷⁻¹⁰ we believe there are clear theoretical arguments against **5** and in favor of **8** for $M = Ca$ and probably for all other known systems of this type. In what follows we present a detailed analysis of the band structure of the $48^2 B_2C_2^{2-}$ net. The calculations are of the Extended Hückel tight-binding type¹⁴ with exponents and parameters given in the Appendix. The analysis of the results will rely heavily on symmetry-based arguments.

Electronic Structure of MB_2C_2

Let us start our discussion considering the two-dimensional boron-carbon net appropriate for CaB_2C_2 . The possible role of lanthanide atoms will be considered later. The density of states

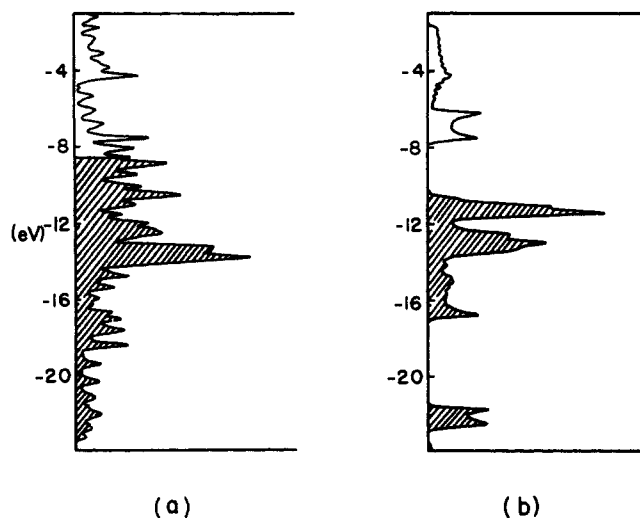

Figure 1. Computed densities of states for (a) coloring I (**5**) and (b) coloring II (**8**) of the 48^2 net.

for the net corresponding to **5**, which we will call I, is shown in Figure 1a. The different bond lengths ($B-B = 1.71 \text{ \AA}$, $B-C = 1.62 \text{ \AA}$, $C-C = 1.31 \text{ \AA}$) were taken as reported for the CaB_2C_2 structure,⁹ and the squares were distorted as reported for LaB_2C_2 ⁸ ($C-B-C = 100^\circ$, $B-C-B = 80^\circ$). Interestingly, there is no gap at the Fermi level. Projection of the different atomic orbital contributions shows that the main component of the DOS in the region near the Fermi level comes from the net's perpendicular π orbitals.

The density of states for the net corresponding to **8**, which we will call II, is shown in Figure 1b. A value of 1.62 \AA (the $B-C$ distance reported for CaB_2C_2) was taken for all $B-C$ distances. As can be seen, there is a very sizable gap (2.8 eV) for the occupation corresponding to $B_2C_2^{2-}$. In molecules the presence of a good HOMO-LUMO gap is often used as an indicator of electronic stability. In solids too there is the general idea of linking stability with the filling of the electron states up to a band gap.¹⁵ The result of our numerical computations confirms the intuitive idea that the coloring II should be more stable than I. In order to quantify in some way the consequences of opening a gap at the Fermi level in this structure and given the well-known deficiencies of the Extended Hückel method when dealing with bond length changes, we repeated the calculations using a common geometry for both colorings. A common distance of 1.62 \AA and regular squares were used. The exponents and parameters used are those of "real" boron and carbon atoms (see Appendix). The coloring II is preferred by 2.09 eV per $B_2C_2^{2-}$ unit, confirming our previous conclusions. It could be argued that by proceeding in this way the net I is disfavored. While in II all distances are close to the value they should have, in I the $B-B$ and $C-C$ used in this model are not as appropriate. In order to overcome this problem, we repeated the calculations using a network with all distances equal and the same exponents for all atoms. The two colorings were simulated with different electronegativities for the two atoms. In practice, different values for the H_{ii} 's were included. These were chosen to be those of boron and carbon. The result is that the coloring II is favored by 2.28 eV per $B_2C_2^{2-}$ unit. A series of calculations with different geometries (changes in the bond lengths, distortion of squares to rhombuses) and parameters (different or common H_{ii} 's) always give the same result: absence/existence of a gap for coloring I/II and preference of II over I by about 2 eV . These results clearly show that the preference for coloring II is an intrinsic property of the net.

To understand why this is so, we turn our attention to the band structures for the two colorings. All results to be discussed henceforth correspond to calculations using exactly equivalent

(13) See Section VI of ref 1 for a further discussion of this problem.

(14) Whangbo, M.-H.; Hoffmann, R. *J. Am. Chem. Soc.* **1978**, *100*, 6093.

(15) See, for example: Pohl, H.; Klose, W.; Anderson, O. K. In *Superconductivity of Ternary Compounds*; Fischer, O., Maple, M. B., Eds.; Springer-Verlag: Berlin, 1982.

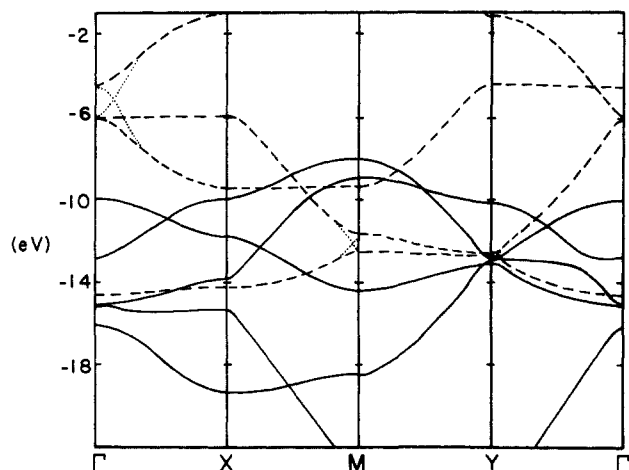
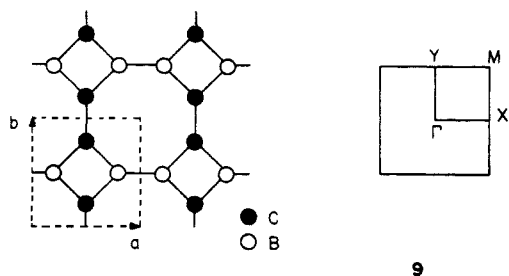

Figure 2. Computed band structure for the coloring I (5). π bands are dashed for clarity.

networks (i.e., a common geometry built from a unique distance and equal exponents for the orbitals at each point of the net). Calculations using "real" atoms give equivalent results.



The unit cell and the Brillouin zone corresponding to coloring I are shown in 9. The dispersion associated with various levels along the different lines defining the irreducible Brillouin zone is shown in Figure 2. As mentioned before, the major contributors to the DOS near the Fermi level for I are the π orbitals. We will focus our attention on the π bands. These bands will be built from the well-known π orbitals of 6 (where X is more electronegative than Y) shown in 10.

With the electron counting for $B_2C_2^{2-}$ only two of the π bands should be occupied. In fact the second and third π bands cross and this lies at the heart of the instability of the structure. It

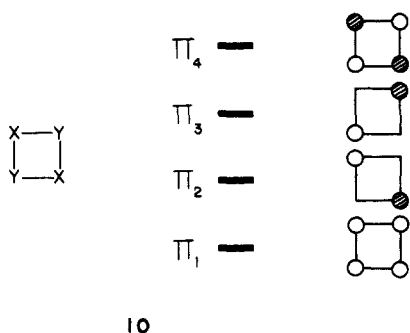

10

should be pointed out that the σ bands, which appear very near the Fermi level, appear at higher energies with respect to the calculation using "real" exponents and parameters.

To understand the reasons for the instability of I, we need to consider the second and third π bands. At the Γ point they will be built from in-phase combinations in all directions of the π_2 and π_3 orbitals 11. These bands represent an in-phase combination of π^* orbitals from pairs of atoms on adjacent squares along the a (11a) or b (11b) directions. In consequence, these bands appear at high energy, the band built from π_3 being at higher energy because of the electronegativity difference. When going from Γ ($k_x = 0, k_y = 0$) to X ($k_x = 1/2, k_y = 0$) the phase relationship of the crystal orbitals changes along a but not along b . Conse-

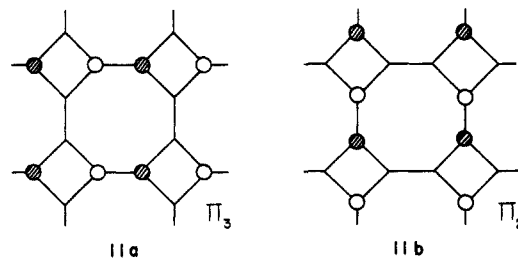

quently, the antibonding interactions between adjacent cells in 11a (π_3 band) define bonding interactions (12a), and the band

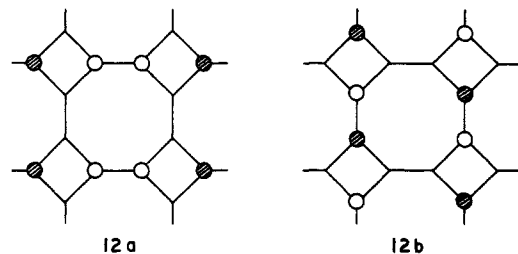

is strongly stabilized along $\Gamma \rightarrow X$. In contrast, 11b with interactions only along b remains unaltered 12b. Moving from X ($k_x = 1/2, k_y = 0$) to M ($k_x = 1/2, k_y = 1/2$) there are phase changes only along the b direction and consequently the orbitals at M will be as shown in 13.

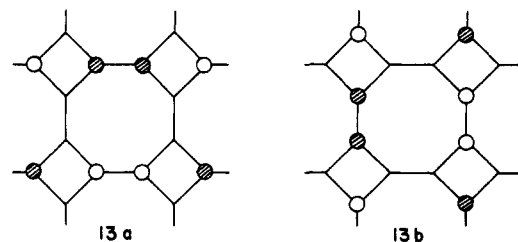

Since a symmetry plane perpendicular to the network and parallel to a is conserved along $\Gamma \rightarrow X$ and because of the different behavior of orbitals $\pi_2(A)$ and $\pi_3(S)$ with respect to this plane, and π_2 and π_3 bands will cross along $\Gamma \rightarrow X$. The two bands will also cross along the $X \rightarrow M$ line because of the presence of a second symmetry plane perpendicular to the network in the b direction. With this information in mind it is very easy to draw qualitative dispersion curves along the $\Gamma \rightarrow X$ and $X \rightarrow M$ lines (14) that are in excellent agreement with the computed results of Figure 2.

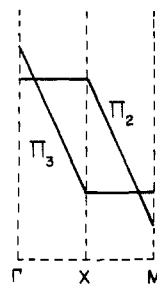

14

It is clear that the absence of a gap at the Fermi level is a consequence not only of the orbital characteristics of four-center rings but also of the fact that the symmetry planes in the unit cell have been conserved in the extended network. The crossing cannot be avoided by distortion of the squares to rhombuses or by making the B-B and C-C distances different. The only way to avoid the crossing would be to lower the whole π_2 band below π_3 . This, in principle, could be achieved by an electronegativity change. However, such a change would imply that an in-phase combination of the π^* orbitals (11b) would be lower in energy than an out-

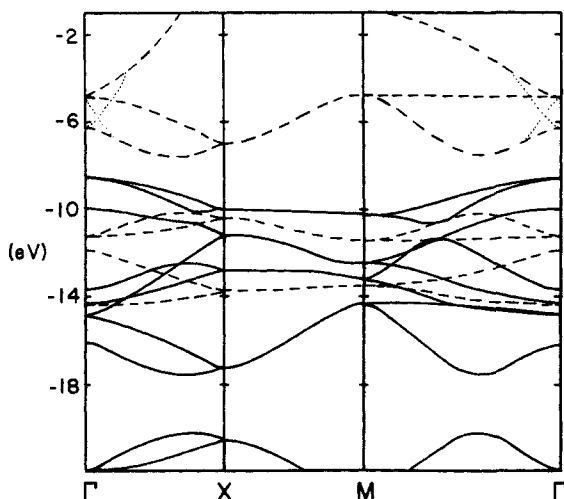
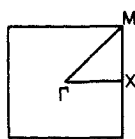
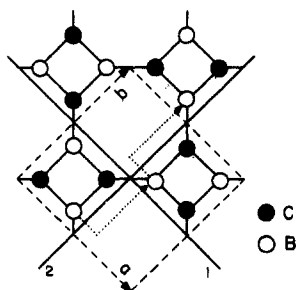

Figure 3. Computed band structure for the coloring II (8). π bands are dashed for clarity.

of-phase combination of π orbitals (13b). As a result there is no way to avoid this crossing.

The unit cell corresponding to the coloring II contains two B_2C_2 units. Consequently there are glide planes and screw axes running parallel to the a and b directions¹⁶ 15. The band structure com-



15

puted for coloring II along the different lines defining the irreducible Brillouin zone is shown on Figure 3. Because of the double unit cell there are eight π bands (only the lowest seven are shown on Figure 3). All bands pair up at the point X and remain doubly degenerate along the $X \rightarrow M$ line. This is a consequence of the existence of these nonsymmorphic elements.¹⁷

The important point to note concerning this band structure is that the second and third groups of π bands do not cross. Intended but avoided crossings along $\Gamma \rightarrow X$ and $M \rightarrow \Gamma$ are obvious in Figure 3. Why these crossings are avoided is simple to see. Because there are two B_2C_2 groups in the unit cell we can build symmetry-adapted combinations of the π orbitals with respect to

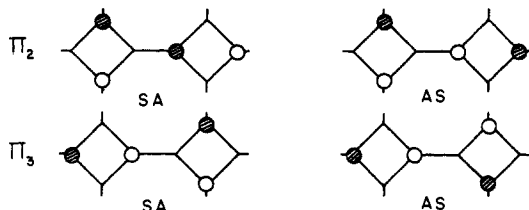

16

the glide planes 16 or with respect to the planes perpendicular to the network and running in the $1/2(a+b)$ direction 17.

Since one glide plane is conserved along the directions $\Gamma \rightarrow X$ and $X \rightarrow M$ and the plane along $1/2(a+b)$ is conserved along $\Gamma \rightarrow M$, one of the crystal orbitals built from π_2 is always of the same symmetry as one of those built from π_3 . These two orbitals

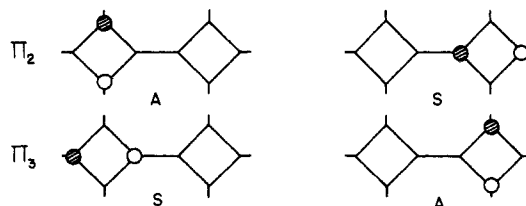

17

mix and the crossing is avoided along the three symmetry lines. The mixing is strong enough to open a gap throughout the Brillouin zone. We can conclude quite firmly that it is the properties of the symmetry groups of the two colorings which regulate their relative stability.

Some additional insight concerning the nature of the extended π -type interactions can be gained by considering a hypothetical net 18. This is a body centered cubic 4.12^2 network¹⁸ where the interring π -type interactions have been removed (of course, some hyperconjugative interactions remain). A calculation for this net with use of the same common distance and exponents as before

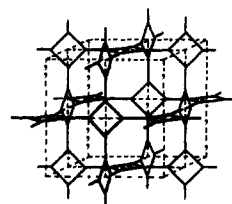

18

and with all contacts between squares being of the B-C type gives an energy per $B_2C_2^{2-}$ unit about halfway between those of I and II. With the previous results for I and II in mind, this suggests that the coloring II is stabilized by the extended π -type interactions which appear as a result of the interaction between the B_2C_2 rings. By contrast the coloring I is destabilized by such π interactions between the rings. (Note that from the electrostatic point of view, coloring I is not favored either.)

The above analysis is valid for CaB_2C_2 . Would the presence of the lanthanide layers modify the results? To answer this question we repeated the calculations using the full 3-D tetragonal structures 5 and 8 where, for the purpose of comparison with the 2-D calculations, the ideal boron-carbon net was used. Structure 8 is favored over 5 by 1.78 eV per B_2C_2La unit which indicates that the lanthanum atoms have a very small influence on the relative stability of the two colorings. Using a rigid band model, we evaluate from this calculation a difference of 1.81 eV for CaB_2C_2 . The difference is maintained for electron counts corresponding to the lanthanide series. This series of results suggests that the lanthanide atoms have only a marginal importance on favoring one or the other structure. Essentially, they act as two-electron donors to the boron-carbon nets, the other electrons remaining in the relative narrow d (or f) bands of the metals.¹⁹

In view of the present results, a careful reexamination of the LnB_2C_2 structures is warranted. CaB_2C_2 is especially interesting in that the conducting and optical properties of the structural alternatives should be drastically different for samples of sufficient purity. Here the coloring problem impinges on more than questions of structural preferences but leads to clear-cut distinctions in physical properties. We recall the prediction made in ref 1 that the stable coloring of the B_2C_2 network should depend upon electron count. Specifically for the quarter and three-quarter filled bands, the stable species should be the opposite to that found

(18) Wells, A. F. *Three-Dimensional Nets and Polyhedra*; Wiley: New York, 1977.

(19) It is interesting to point out that if the metal atoms were acting as a three-electron donor a different planar network (that present in ScB_2C_2 , structure 3) might result: Burdett, J. K.; Lee, S. *J. Am. Chem. Soc.* 1985, 107, 3063. This result relies on the assumption that the structural choice is dominated by the electronic effects. Metal size effects can also play a role in this choice.

(16) The glide planes are indicated by the continuous lines 1 and 2. The combined effect of the reflection plus semitranslation (glide plane) is indicated by dotted arrows.

(17) Herring, C. *Phys. Rev.* 1937, 52, 361, 365.

for the half-filled case. Removal of electrons from CaB_2C_2 eventually leads to emptying of the σ levels, and so our computed results here have no meaning, but for the $B_2C_2^{-4}$ system the opposite structure to that predicted for $B_2C_2^{2-}$ is indeed calculated to be more stable.

Molecular Analogy

Orbital interaction analyses of the electronic structure of organic and organometallic molecules have proven to be very illuminating.²⁰ The same type of arguments can often be found²¹ hidden in the band theoretic language used to analyze the electronic structure of solids. Consideration of molecular analogies is often useful in guiding our understanding of the electronic structure of solids. Here we point out a molecular analogue of the structural choice in MB_2C_2 systems.

In the parent unsubstituted 48^2 2-D network **19**, all atoms are equivalent. As a consequence, the π_2 and π_3 orbitals of the repeat unit are degenerate. When building the crystal orbitals of the extended system using these two orbitals as a basis, we will find that the two crystal orbitals **11a** and **11b** as well as **13a** and **13b** are also equivalent (i.e., degenerate). The qualitative band structure of **14** then changes to that shown in **20**. There is no

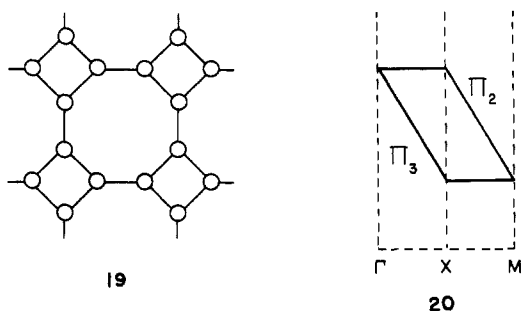

gap at the Fermi level with four π electrons per repeat until where this collection of bands is half full. A lowering of the symmetry toward I is ineffective in opening a gap at the Fermi level. By contrast, lowering the symmetry toward II results with a band gap and the structure is strongly stabilized.

Obviously the choice between structures **5** and **8** is the solid-state analogue of the old organic chemistry problem: how to stabilize a singlet cyclobutadiene?⁶ From the two ways to lower the symmetry **6** and **7**, only the first one effectively opens a gap because both the π_2 and π_3 orbitals can be restricted to one of the π X or Y subsystems **21**. It is then the electronegativity difference which creates the gap.

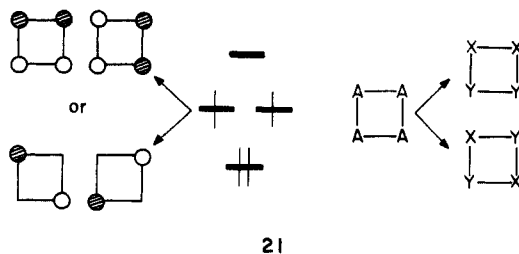

Coloring in a 6^3 Net: Boron Nitride

Our analysis of the MB_2C_2 problem shows the utility of careful consideration of symmetry properties in understanding the results of band structure calculations. We would like to point out that this is not just a peculiarity of the 48^2 net. Similar considerations can be applied to very different systems, for example, to phase transformations in solids.²²

A problem related to that of the coloring choice in MB_2C_2 is that of the distribution of boron and nitrogen atoms in hexagonal boron nitride (i.e., coloring in an isoelectronic 6^3 two-dimensional net). A series of model calculations was performed for an ideal graphite network. (The exponents for every atom in the network were identical, and the different coloring simulated by changing the electronegativity of the different centers.) The experimentally observed coloring **22** was found to be substantially more stable than the rival colorings **23** and **24**.

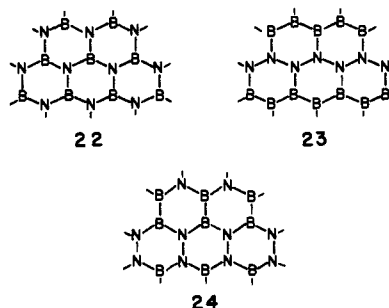

It is interesting to note that it is only for coloring **22** that a gap develops at the Fermi level, and this fact is clearly related to the stability of this system, i.e., it is the observed one. The absence of a gap in the parent 6^3 net (graphite) is due to the well-known degeneracy of the π levels at the point K in the Brillouin zone. At this point the phase factor is simply $\exp(ik \cdot R_i) = \exp(i(2\pi/3)(l_1 + l_2))$. The π crystal orbitals of the system may then readily be generated by repeating the π and π^* orbitals of the unit cell according to this phase factor, **25** and **26**. Because of the de-

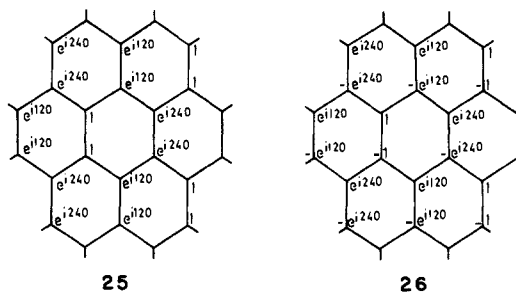

generacy of these two orbitals—a consequence of the existence of a screw axis along a_1 and a_2 —we can choose a different set of mutually orthogonal crystal orbitals. A sum and difference of **25** and **26** localize the new crystal orbitals in two equivalent and independent subsets (starred and unstarred in **27**) of the 6^3 net. Obviously the most efficient way to open a gap and consequently to stabilize the structure is to lower the symmetry of the net by taking advantage of the pattern in **27** which results in the experimental coloring **22**.

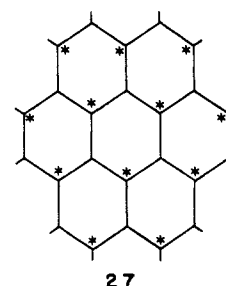

Although the similarity between the boron nitride and substituted cyclobutadiene problems is already evident, the relation with the MB_2C_2 cases is probably less evident. We recall that the 48^2 net is composed of a series of condensed squares and octagons. Because of its cyclic nature, the central pair of π orbitals of planar cyclooctatetraene (π_4 and π_5) can also be localized in two independent and equivalent sets. Consequently, the best way to open a gap in the half-filled 48^2 net is by doing an electronegativity perturbation such that two independent and alternate

(20) Albright, T. A.; Burdett, J. K.; Whangbo, M.-H. *Orbital Interactions in Chemistry*; Wiley: New York, 1985.

(21) Whangbo, M.-H. In *Crystal Chemistry and Properties of Materials with Quasi One-Dimensional Structures*; Rouxel, J., Ed.; Reidel: New York, 1985. Hughbanks, T.; Hoffmann, R. *J. Am. Chem. Soc.* **1983**, *105*, 3528.

(22) Burdett, J. K.; Lee, S. J. *Solid State Chem.* **1982**, *44*, 415. Burdett, J. K.; Canadell, E., unpublished results.

Table I

atom	orbital	H_{ii} (eV)	ζ_1	ζ_2	c_1^a	c_2
B	2s	-15.2	1.30			
	2p	-8.5	1.30			
C	2s	-21.4	1.625			
	2p	-11.4	1.625			
N	2s	-26.0	1.95			
	2p	-13.4	1.95			
La ²⁴	6s	-7.67	2.14			
	6p	-5.01	2.08			
	5d	-8.21	3.78	1.38	0.7766	0.4587

^aContraction coefficients used in the double- ζ expansion.

sets of points (both in the squares and octagons) are created. The possibility of creating two independent and electronically equivalent sets of orbitals near the Fermi level (at the HOMO) level is the common link between the cyclobutadiene, boron nitride, and MB₂C₂ problems.

Acknowledgment. We thank the donors of the Petroleum Research Fund, administered by the American Chemical Society, for their partial support of this research. Our work was also supported by the National Science Foundation NSF DMR 8019741.

Appendix

The calculations are of the Extended Hückel type^{23,24} with the parameters and exponents of Table I. The modified Wolfsberg-Helmholz formula²⁵ was used. The results for the ideal nets for I and II reported in Figures 2 and 3 were obtained with use of a common distance of 1.62 Å, exponents ζ_{2s} and ζ_{2p} of 1.30, and the H_{ii} values for B and C (Table I). Calculations for the ideal 6³ net were carried out with use of a common distance of 1.42 Å, exponents ζ_{2s} and ζ_{2p} of 1.625, and the H_{ii} values for B and N. k -point meshes used in the calculations were as follows: 64 k -points for type I net; 55 k -points for type II net; 40 k -points for **18**; 55 k -points for **22**; and 64 k -points for **23** and **24**. Each of the k -points meshes are referred to the number of points computed in the irreducible wedge of the appropriate Brillouin zone. The DOS curves of Figure 1 were smoothed with Gaussian functions with a standard deviation of 0.08 eV.

Registry No. CaB₂C₂, 69106-69-0; B₂C₂La, 12678-10-3; boron nitride, 10043-11-5.

(23) Hoffmann, R. *J. Chem. Phys.* **1963**, *39*, 1397.

(24) Zheng, C.; Hoffmann, R., unpublished results.

(25) Ammeter, J. H.; Bürgi, H. B.; Thiebaud, J.; Hoffmann, R. *J. Am. Chem. Soc.* **1978**, *100*, 3686.

Tying Knots around Chiral Centers: Chirality Polynomials and Conformational Invariants for Molecules

Paul G. Mezey

Contribution from the Department of Chemistry, and Department of Mathematics, University of Saskatchewan, Saskatoon, Saskatchewan, Canada S7N 0W0. Received November 14, 1985

Abstract: A method is proposed for the description and analysis of chirality properties of molecules with any number of chiral carbon centers. By using a simple algorithm, chirality information of molecules can be transferred to various knots which are in turn described by polynomials. These polynomials are remarkably simple, and they are invariant to conformational changes and provide an easy test for various types of chirality properties even for molecules of a large number of chiral centers. Several examples are discussed in some detail.

There have been several approaches to provide simple algebraic models for the description of molecular chirality; most recent works include various group theoretical approaches¹⁻⁶ which have given new insight and new methodology for such analyses. In this study we shall describe an intuitively simple (one may be tempted to say, playful) approach that, nonetheless, leads to a rigorous algebraic description of chirality in terms of simple polynomials.

A recent discovery of a set of polynomials describing the shapes, and, in particular, the chirality properties of knots of various types^{7,8} is expected to have important implications in a variety of applied fields. Whereas the full development of these poly-

nomials has required rather sophisticated mathematical techniques, nonetheless, their appreciation and intuitive understanding requires no more than high school mathematics and their application is extremely simple. In fact, their actual generation and application to the chirality problems of chemistry, addressed in this study, require no more than an understanding of what is polynomial and some practical skills in handling a string when tying knots around ball-and-stick molecular models.

In chemistry, chirality is of fundamental importance, appreciated by both chemists and mathematicians. This is well-illustrated by the fact that the very first chemical application of these new polynomials has already been described by one of the original discoverers of the new polynomials.⁹ This application has led to a description of chirality of *cyclic chain molecules which themselves form loops, knots, and links* such as the molecules recently synthesized by Walba.¹⁰ Although these molecules occur rarely in nature, they are of special theoretical interest. The same technique is also expected to find applications in processing electron

(1) Ruch, E.; Schonhofer, A. *Theor. Chim. Acta* **1968**, *10*, 91. Ruch, E.; Schonhofer, A. *Theor. Chim. Acta* **1970**, *19*, 225. Ruch, E.; Hässelbarth, W.; Richter, B. *Theor. Chim. Acta* **1970**, *19*, 288.

(2) Klein, D. J.; Cowley, A. H. *J. Am. Chem. Soc.* **1978**, *100*, 2593.

(3) Ruch, E. *Acc. Chem. Res.* **1983**, *5*, 49.

(4) Ruch, E.; Klein, D. J. *Theor. Chim. Acta* **1983**, *63*, 447.

(5) Mislow, K.; Siegel, J. *J. Am. Chem. Soc.* **1984**, *106*, 3319.

(6) Anet, F. A. L.; Miura, S. S.; Siegel, J.; Mislow, K. *J. Am. Chem. Soc.* **1983**, *105*, 1419.

(7) Jones, V. F. R. *Bull. Am. Math. Soc. (NS)* **1985**, *12*, 103.

(8) Lickorish, W. B. R.; Millett, K. C. Mathematical Sciences Research Institute, 1985, preprint 04212-85. Freyd, P.; Yetter, D.; Hoste, J.; Lickorish, W. B. R.; Millett, K.; Ocneanu, A. *Bull. Am. Math. Soc. (NS)* **1985**, *12*, 239. Earlier works that have led to the new developments include Alexander, J. W. *Proc. Natl. Acad. Sci. U.S.A.* **9**, 93, **1923**, and An enumeration of knots and links, Conway, J. H. *Computational Problems in Abstract Algebra*; Pergamon Press: New York, 1970; pp 329.

(9) Millett, K. C. Presented at the IUPAC International Symposium on Applications of Mathematical Concepts to Chemistry, Dubrovnik, Yugoslavia, Sept 1985; to be published.

(10) Walba, D. M. *Stereochemical Topology*; King, R. B., In Chemical Applications of Topology and Graph Theory, Elsevier: Amsterdam, 1983. A related early study on similar molecules is described by Wasserman (Wasserman, E. *J. Am. Chem. Soc.* **1960**, *82*, 4433) and by Frisch and Wasserman (Frisch, H. L.; Wasserman, E. *J. Am. Chem. Soc.* **1961**, *83*, 3789).